

# Panasonic

DXG Series

## DXG Series Steam-fired Single Effect LiBr Absorption Chiller

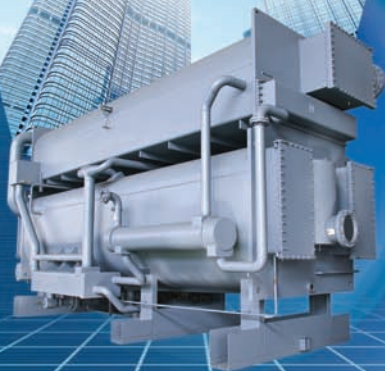

# SUPER G ABSORPTION

High Performance High reliability



## DXG Series (100~1984USRT)

### Steam-fired Single Effect LiBr Absorption Chiller

Modern industrial development creates great material wealth for mankind, while also generates a lot of waste heat, waste of energy, with the thermal pollution of the environment. Owing to 50 years of innovation and manufacturing experience. Panasonic Appliances Air-Conditioning and Refrigeration (Dalian) Co., Ltd. launched a new series of DXG Steam-fired Single Effect LiBr Absorption Chiller, which could match to low-pressure 0.01-2 kilograms steam occasion. It takes use of waste heat to achieve high efficient, environmental friendly, safe and reliable operation by mature technology. Mainly provide cooling source for large scale central air conditioning system and other places needing chilled water, widely applied in office building, hotel, department store, cinema, stadium and factory, etc.

### Particularly suitable for the following applications:

- Power plant with waste heat
- Factories with waste heat boiler (industries process air conditioning in iron and steel factory, petrochemical factory etc.)
- User with waste heat of industries process (factory building cooling model)
- Match to 0.01-2 kilograms steam occasion



## Absorption chiller flow diagram

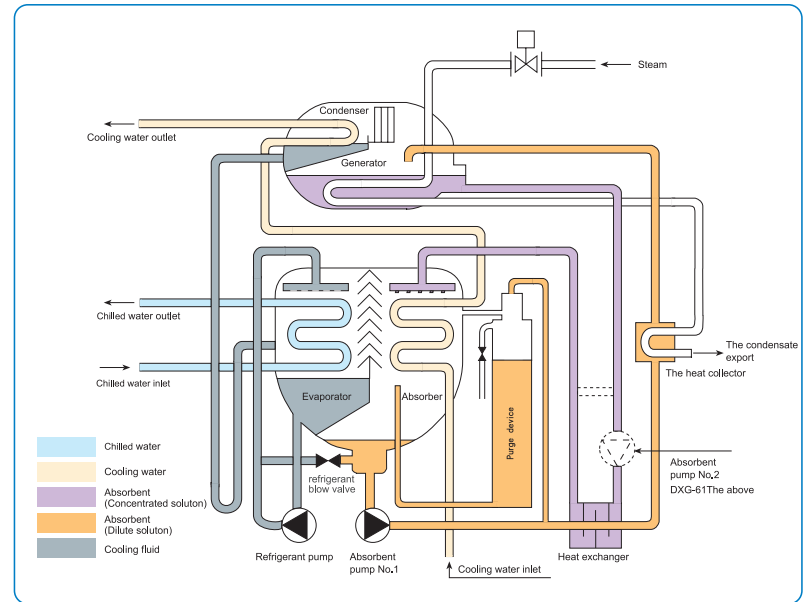

Our DXG Steam-fired Single Effect LiBr Absorption Chiller is made of evaporator, absorber, condenser, generator, heat exchanger, heat reclaimer, solution pump and refrigerant pump etc.

Principle of operation: chilled water is cooled in evaporator by low temperature refrigerant which has been decompressed and throttled from condenser, and the refrigerant is turned into vapour after absorbing the heat of chilled water, and then is absorbed into absorber where the concentrated solution is turned into dilute solution.

The dilute solution in the absorber is pumped through heat exchanger, heat reclaimer where the solution temperature goes up, to the generator at last, where the dilute solution is heated and condensed into concentrated solution.

The concentrated solution flows through heat exchanger where the temperature goes down, then into the absorber and is sprayed on the cooling water tubes where it absorbs the refrigerant vapour coming from evaporator and is turned into dilute solution. On the other hand, the vapour in the generator produced by heating lithium-bromide solution floats into condenser then cooled into low temperature refrigerant after being decompressed and throttled, flows into evaporator where it is sprayed on the condensed coils, cool the chilled water in the evaporator.

Above process circles again and again for producing chilled water continuously.

## Features

### Optimize structural design to raise heat efficiency

Adopt new patent heat exchange tube, new across counter flow heat exchanger, internal vacuum heat insulation layer, and internal refrigerant self-adjusting device to raise heat efficiency and maximize the use of waste heat resources.

### Vacuum heat insulation layer in upper shell, reduces internal heat loss.

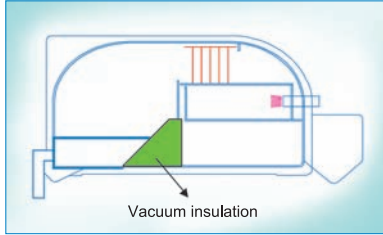

### Internal refrigerant self-adjusting cooling storage device

- Adapt to changes in load, self-adjusting, automatically add the refrigerant in evaporator "cooling storage" to achieve the maximize energy-saving operation.
- Shorten the start time of the machine
- Shorten the dilution operation time
- Suit much lower cooling water inlet temperature
- Prevent cavitation erosion of refrigerant pump to extend the service life of the pump.

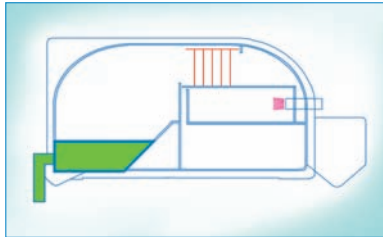

### Unit specific design to achieve load stability, adequacy.

Specially adapt to the requirements of stability and adequacy load of craft air conditioning, adopts new control system, internal refrigerant self-adjusting cooling storage device, quick heat state balance circulation technology to realize stable, high efficient operation.

### High accuracy control, stable performance

- New speed type PID control, accuracy much higher, can be quick responsive to sudden load change.
- Adopt upper/ lower shell quick pressure parting technology, use pin throttle and u-type throttling circuit to accurately control refrigerant flow.
- New level control optimizes generator control
- Safer accurate generator temperature control

### New PID control operation

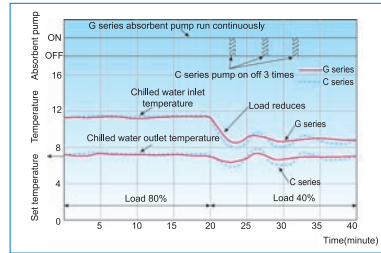

### Generator temperature high safety control

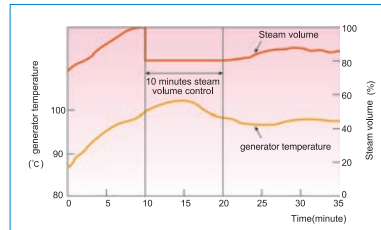

- Adopt new bow wave spray automatic purge device and five vacuum keeping designs.
- Adopt automatic safety protection control systems, corresponding to 19-34°C cooling water, and solution concentration security control system to expand the operation range, and make safety protect operation function running more perfectly.

## Features

- The micro-computer monitors the temperature and concentration of the solution and adjust solution flow rate and steam volume, which make solution circulation far from crystallization zone, and at the same time adopt cold state generation technology, auto-decrystallization technology using of four crystallization prevention safety control to prevent crystallization completely.
- Unit adopts self-diagnosis professional function, supplying foresee information of cooling water system heat transfer tube fouling state, absorbent concentration up trend and vacuum state time monitor to keep a steady operation.

### ② Absorbent concentration up trend

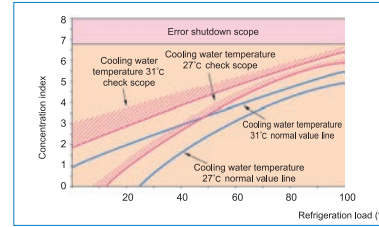

### ① Cooling water system heat transfer tube fouling state

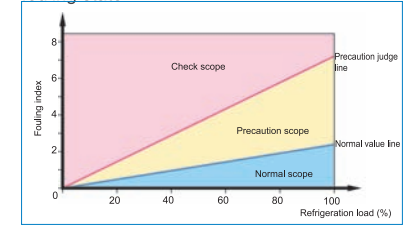

### ③ Vacuum state time monitor

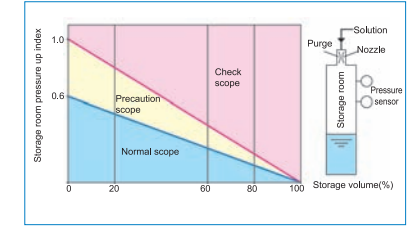

## Specifications

### DXG Series (Steam Pressure 1.5Kg/cm<sup>2</sup> · G)

Model		DXG-	11	12	13	14	21	22	23	24	31	32	41		
Refrigeration capacity	USRT	100	120	150	180	210	240	280	320	360	400	450			
	10 <sup>3</sup> kcal/h	302	363	454	544	635	726	847	968	1,089	1,210	1,361			
	kW	352	422	527	633	738	844	985	1,125	1,266	1,407	1,582			
Chilled water system temperature inlet: 12°C temperature outlet: 7°C	Flow rate	m <sup>3</sup> /h	60.5	72.6	90.7	109	127	145	169	194	218	242	272		
	Pressure drop	mH <sub>2</sub> O	6.2	6.4	8.6	8.6	7.6	8.1	5.3	5.8	6.2	6.6	5.8		
	Inlet/outlet connection	A	100				125			150			200		
Cooling water system temperature inlet: 32°C temperature outlet: 39.4°C	Flow rate	m <sup>3</sup> /h	100	120	150	180	210	240	280	320	360	400	450		
	Pressure drop	mH <sub>2</sub> O	4.8	5.4	5.0	6.1	5.0	5.7	9.7	10.9	7.4	7.9	8.7		
	Inlet/outlet connection	A	125				150			200			250		
Steam system	Steam consumption	kg/h	780	936	1,170	1,404	1,638	1,872	2,184	2,496	2,808	3,120	3,510		
	Steam inlet connection	A	125				150			200					
	Drain outlet connection	A	40						50			65			
	Steam control valve connection	A	50		65		80			100					
Power 3φ, 380V, 50Hz	Total currency	A	7.6				9.1		9.6		12.4				
	Wire area	mm <sup>2</sup>	4.0												
	Power consumption	kVA	5.8				7.0		7.4		9.7				
Motor	No.1 absorbent pump	kW(A)	1.1(3.9)				1.5(5.4)				3.0(8.2)				
	No.2 absorbent pump	kW(A)	.....												
	Refrigerant pump	kW(A)	0.2(1.3)						0.4(1.8)						
	Purge pump	kW(A)	0.4(1.2)												
Overall dimension	Length	mm	2,680		3,690		3,770		4,850		4,910		4,960		
	Width	mm	1,295				1,455				1,515				1,615
	Height	mm	2,175				2,345				2,545				2,855
	Clearance space	mm	2,400			3,400				4,500					
Weight	Operation weight	ton	3.8	4.0	4.9	5.1	6.2	6.5	7.6	8.0	9.8	10.2	11.8		
	Max. moving weight	ton	3.3	3.5	4.3	4.5	5.4	5.6	6.6	6.9	8.5	8.8	10.1		
	Total weight	ton	3.3	3.5	4.3	4.5	5.4	5.6	6.6	6.9	8.5	8.8	10.1		
	Moving state		One - section												

Water maintained in machine	Chilled water system	113	127	148	170	216	235	274	298	333	354	451
	Cooling water system	1	342	373	427	474	595	650	713	785	990	1,060

Note: (1) 1 USRT=3,024kcal/h=3.52kW

(2) Standard chilled water inlet/outlet temperature is 12°C→7°C (Standard inlet/outlet temperature difference is 5°C).

(3) Standard cooling water inlet/outlet temperature is 32°C→39.4°C (Standard inlet/outlet temperature difference is 5.7°C).

(4) Standard pressure of input steam: 1.5, is the pressure before entry control valve. When steam pressure deviates from the standard pressure, please check with Panasonic Appliances Air-Conditioning and Refrigeration (Daikin) Co., Ltd.

(5) Max. working pressure in chilled water and cooling water system: 8kg/cm<sup>2</sup> · G. High pressure model is available, dimension and foundation may be changed, so please enquire with the manufacturer.

## Specifications

42	51	52	53	61	62	63	71	72	73	81	82	83	84
500	560	630	700	800	900	1,000	1,100	1,200	1,300	1,400	1,500	1,653	1,984
1,512	1,693	1,905	2,117	2,419	2,722	3,024	3,326	3,629	3,931	4,234	4,536	5,000	6,000
1,758	1,969	2,215	2,461	2,813	3,165	3,516	3,868	4,220	4,571	4,923	5,274	5,815	6,978
302	339	381	423	484	544	605	665	726	786	847	907	1,000	1,200
5.1	4.6	6.2	8.0	5.5	7.4	9.7	6.4	8.2	10.1	8.2	9.9	10.1	9.9
200				250			300			350			400
500	560	630	700	800	900	1,000	1,100	1,200	1,300	1,400	1,500	1,631	1,958
9.3	5.7	7.6	9.6	6.7	8.7	11.2	8.0	10.0	12.2	10.5	12.6	11.4	12.4
250	300			350			400			450			
3,900	4,368	4,914	5,460	6,240	7,020	7,800	8,580	9,360	10,140	10,920	11,700	12,632	15,159
200	250		300				350			400		450	
65			80						100			125	
125				150				200					
12.4					27.1			33.3				60.4	
4.0					6.0			10.0				25.0	
9.7					21.8			26.9				49.2	
3.0(8.2)				5.5(16.5)					15.0(39.0)				
.....					1.8(6.4)			3.7(12.0)					
0.4(1.8)										1.8(6.4)			
0.4(1.2)						0.75(1.8)							
4,960	5,050	5,590	6,090	5,750	6,250	6,770	6,455	6,980	7,480	7,080	7,580		
1,615	1,950			2,340			2,950				3,020	3,490	
2,855	3,200			3,730			3,930			4,000		4,140	4,090
4,500	4,600	5,200	5,700	5,200	5,700	6,200	6,000	6,500	7,000	6,500	7,000	7,100	
12.3	17.2	18.7	20.1	24.3	25.9	28.1	33.5	35.3	37.4	40.1	42.7	49.3	53.7
10.4	14.5	15.8	17.0	21.3	22.3	24.2	22.7	23.7	25.0	26.8	28.2	29.8	31.9
10.4	14.5	15.8	17.0	21.3	22.3	24.2	28.0	29.5	31.3	33.4	35.7	41.2	44.5
One - section							One - section Solution of the other place				Moving separately		

478	648	707	762	1,060	1,140	1,220	1,450	1,550	1,650	1,800	1,920	2,253	2,579
1,346	2,022	2,175	2,313	2,970	3,230	3,430	4,020	4,250	4,460	4,830	5,080	5,807	6,616

(6) Range of chilled/cooling water flow: 50~120%.

(7) "A" stands for nominal diameter, unit is mm.

(8) Steam control valve is electric powered.

(9) Control panel specifications named in different ways: LED type and Touch type.

(10) And, the values in above table may be modified without notice.

## Order scope

ITEM		STANDARD SPECIFICATIONS	OPTIONS
Chilled water system	Flow rate	0.605m <sup>3</sup> /h · RT (Δt=5°C constant quantity)	Range of variable flow: 50~120%
	Temperature	12/7°C	Special inlet/outlet temperature of chilled water
	Water quality	Tap water (according to JRA 9001)	Industrial water, well water
Cooling water system	Max. working pressure	8Kg/cm <sup>2</sup> · G	Pressure1:10 kg/cm <sup>2</sup> · G Pressure2:14 kg/cm <sup>2</sup> · G Pressure3:16 kg/cm <sup>2</sup> · G Pressure4:18 kg/cm <sup>2</sup> · G Pressure5:20 kg/cm <sup>2</sup> · G
	Flow rate	1.0 m <sup>3</sup> /h · RT (Δt=7.4°C constant quantity)	Range of variable flow: 50~120%
	Temperature	32/39.4°C (Lower inlet temperature limit: 19°C)	Inlet temperature: 20~33°C
	Water quality	Tap water (according to JRA 9001)	Industrial water, well water
Installation place	Max. working pressure	8Kg/cm <sup>2</sup> · G	Pressure1:10 kg/cm <sup>2</sup> · G Pressure2:14 kg/cm <sup>2</sup> · G Pressure3:16 kg/cm <sup>2</sup> · G Pressure4:18 kg/cm <sup>2</sup> · G Pressure5:20 kg/cm <sup>2</sup> · G
	Place	In machine room	
	Appearance	Main body: anti-rusting paint (exclusive of heat or cooling insulation, final paint)	
	Ambient temperature	5/40°C	
package	Ambient humidity	Relative humidity: below 90%	
	Mode	One section	Moving separately
Power	Frequency/voltage	3φ/380V/50Hz	
	Voltage regulation	within 10%	
Electric wiring	Type	Cable wiring Control: cable Power: cable	
Main body safety device	Type	Refrigerant temperature supervision function Chilled water freezing protection function Generator temperature supervision function Generator pressure supervision function Generator solution level supervision function Motor protection function Cooling water temperature supervision function Chilled water flow switch Crystal protection function	Cooling water flow switch
Capacity control device	Mode	Speed type digital PID control by chilled water outlet temperature	
Control panel	Paint	Munsell 5Y-7/1 (half smooth)	
	Display	LCD English display	Touch screen
	Outside wiring terminals	Operation indication-point a Stop indication-point a Alarm indication-point a Auxiliary equipment operation-point a Start confirmation-point a Cooling operation indication-point a (non-voltage connection)	
Purge device	Mode	Liquid injector make non-condensable gas be stored in the tank and exhaust continuously hydrogen	
Steam system	Steam quality	Refer to JISB 8223-2006, GB 1576-2008 and GB 12145-2008	
	working pressure	1.5 kg/cm <sup>2</sup> · G (Saturated)	0.01~2.0kg/cm <sup>2</sup> · G (Sturated)

## Supply scope



Item		Delivery construction	Customer construction	Note
① Body	Absorption Chiller	○		Reference to the caption below the chart
② Transportation and installation	From the factory to the building		○	
	From the building to the foundation site		○	
	Installation of chiller		○	
	Testing and adjusting at site	●	○	
③ Electric construction	Operating direction	○		
	External electric allocation		○	Please wire to the terminal inside the control panel
④ Other construction	Cooling water temperature control device		○	Please install and wire for the thermostat used by start-stop fan of cooling tower or for the thermostat of cooling water control valve.
	Foundation construction		○	Exclusive of foundation bolts,weld the frame and washer when fixing foundation bolts.
	External pipe construction		○	
	Pipe anti-freezing		○	Exclusive of coordinate flanges
	Water quality management of cooling water		○	Take anti-freezing of pipe and water into consideration at rest in winter.
	Heat or cooling insulation construction		○	Install water drainage device in order to have a proper water quality management.
⑤ Painting	Steam control valve installation construction		○	Install in the pipe, and wire to terminal inside the control panel.
	Main body primary coat	○		Anti-rusting primary coat
⑥ Others	Control panel painting	○		Munsell No.5Y-7/1(half-smooth)
	Assembly power,water, etc. at site		○	
	Power, water and steam, etc. used during trail run		○	
	Lithium-Bromide solution, refrigerant	○		

### Absorption chiller main body includes

1.Absorption chiller	c.Capacity control device	h.internal piping and electric wiring
a.Machine of refrigeration cycle including evaporator, absorber, generator, condenser, heat exchanger, heat reclaimr, pumps, etc.	d.Steam control valve	2.Assessor
b.Purge device	e.Safety device	a.Foundation bolts and washers-1set
	f.Contron panel	b.Instruction manual-1 set
	g.Absorbent and refrigerant	*Extra charge should be calculated separately if required.

# Overall dimension diagram · Base diagram

## ● Overall dimension diagram

- Note: 1. Overall dimension value (L),(W),(H) is example value.  
 2. Mark  denotes the position of foundation bolts of chiller.  
 3. Clearance space must be saved for either side of the chiller.  
 4. Mark  is the power wire hole.  
 5. Maintenance space must be saved around the chiller.  
 Length direction-----1m Above-----0.2m  
 Control panel direction-----1.2m Others-----0.5m  
 6. "A" stands for nominal diameter, unit is mm.

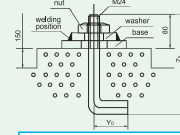

## ● Base diagram

- Note: 1. There are  $\phi 50$  holes under the chiller for foundation bolts.  
 2. When fastening foundation bolts, please welding base and washer together with reference to left diagram.  
 3. Please make a drainage ditch around the chiller.  
 4. Please make the ground water proof in order to maintain the chiller.  
 5. The base must be smooth and horizontal (The levelness should be below 2mm for 1,000mm).

	Y <sub>0</sub>	Z <sub>0</sub>
DXG-11-31	80	260
DXG-32-52	80	340
DXG-53-84	90	440

## DXG-11/12 In ( ) is Model 12

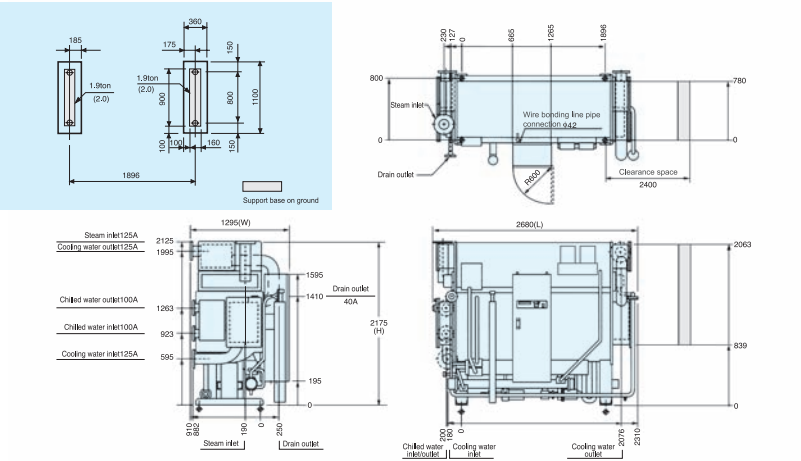

## DXG-13/14 In ( ) is Model 14

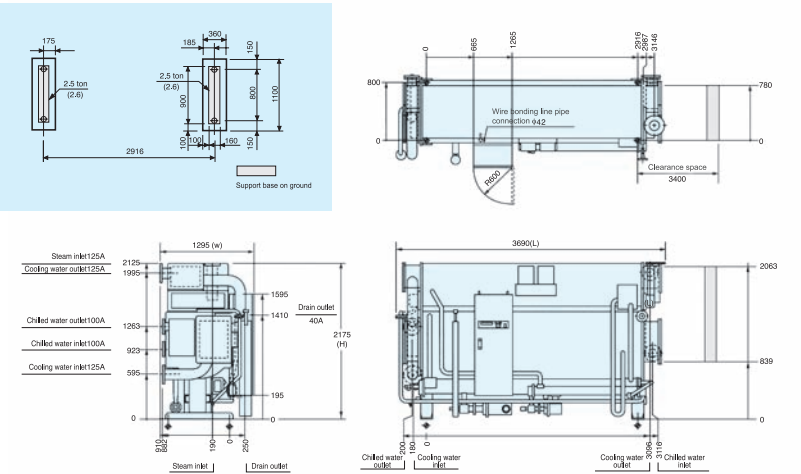

## DXG-21/22 In ( ) is Model 22

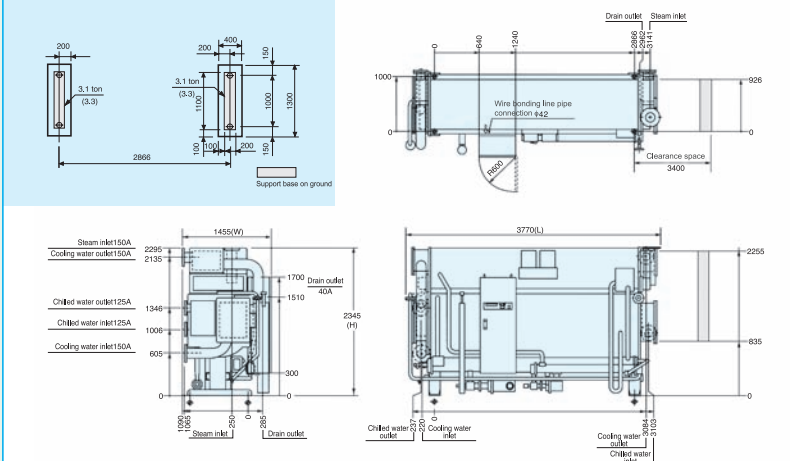

## DXG-23/24 In ( ) is Model 24

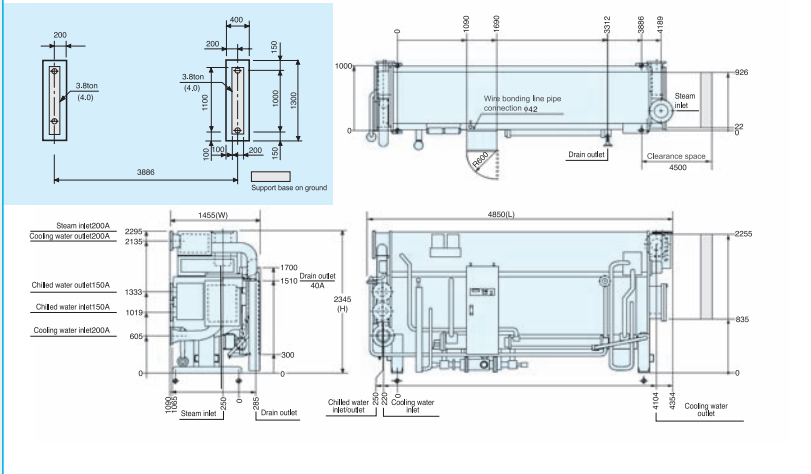

# Overall dimension diagram · Base diagram

## ● Overall dimension diagram

- Note: 1. Overall dimension value (L), (W), (H) is example value.  
 2. Mark  $\oplus$  denotes the position of foundation bolts of chiller.  
 3. Clearance space must be saved for either side of the chiller.  
 4. Mark 1 is the power wire hole.  
 5. Maintenance space must be saved around the chiller  
 Length direction-----1m Above-----0.2m  
 Control panel direction-----1.2m Others-----0.5m  
 6. "A" stands for nominal diameter, unit is mm.

### DXG-31/32 In ( ) is Model 32

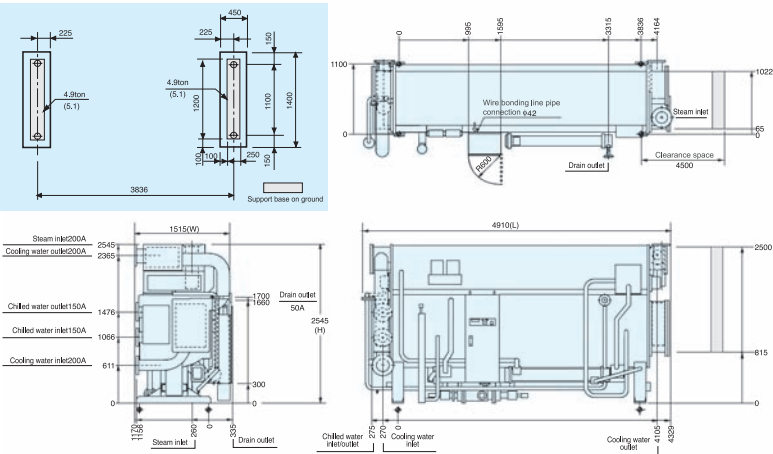

### DXG-41/42 In ( ) is Model 42

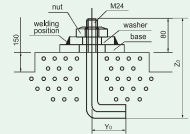
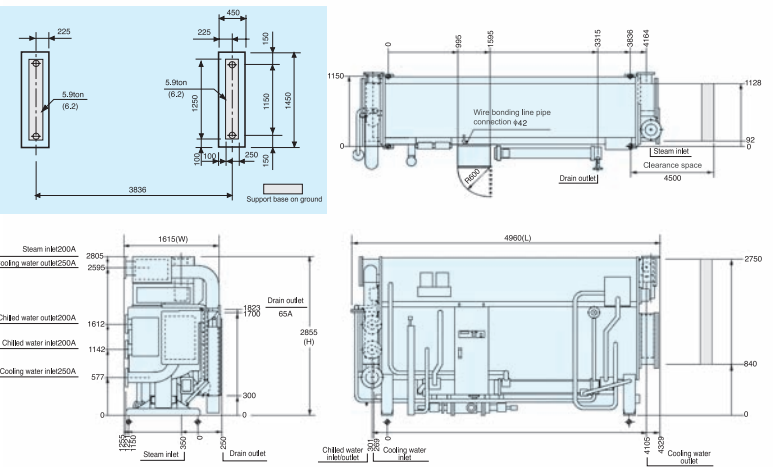

## ● Base diagram

- Note: 1. There are 4 50 holes under the chiller for foundation bolts.  
 2. When fastening foundation bolts, please welding base and washer together with reference to left diagram.  
 3. Please make a drainage ditch around the chiller.  
 4. Please make the ground water proof in order to maintain the chiller.  
 5. The base must be smooth and horizontal (The levelness should be below 2mm for 1,000mm).

	Y <sub>0</sub>	Z <sub>0</sub>
DXG-11-31	80	261
DXG-32-52	80	340
DXG-53-84	90	440

### DXG-51/52/53

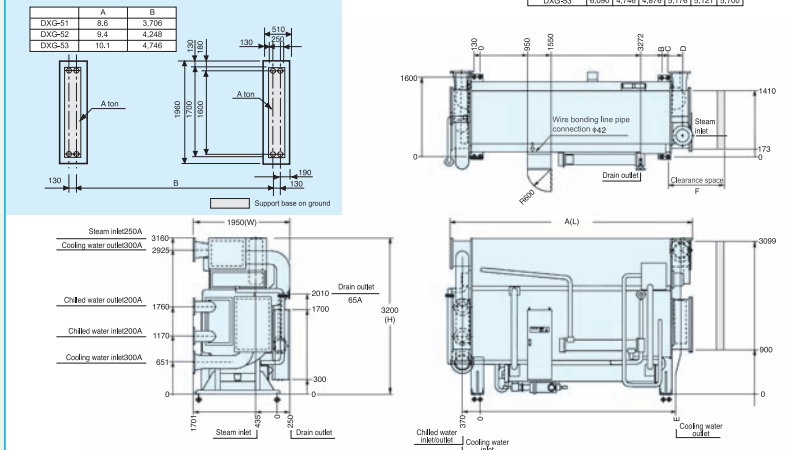

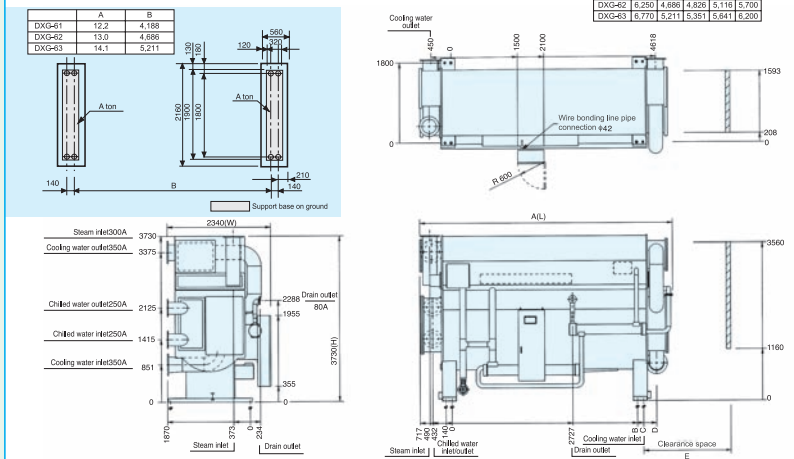

### DXG-61/62/63



## Overall dimension diagram · Base diagram

### ● Overall dimension diagram

- Note: 1. Overall dimension value (L),(W),(H) is example value.  
 2. Mark  denotes the position of foundation bolts of chiller.  
 3. Clearance space must be saved for either side of the chiller.  
 4. Mark  is the power wire hole.  
 5. Maintenance space must be saved around the chiller.  
 Length direction-----1m Above-----0.2m  
 Control panel direction-----1.2m Others-----0.5m  
 6. "A" stands for nominal diameter, unit is mm.

## DXG-71/72/73

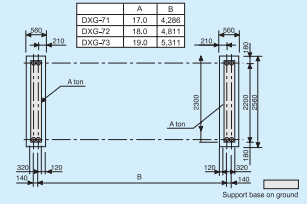

	A	B	C	D	E
DXG-71	6455	4296	4426	5136	6000
DXG-72	6980	4811	4951	5651	6500
DXG-73	7480	5311	5451	6161	7000

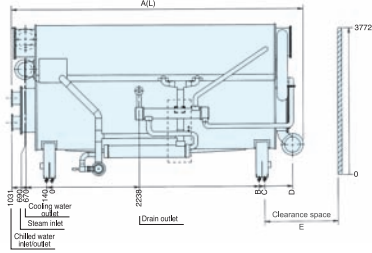
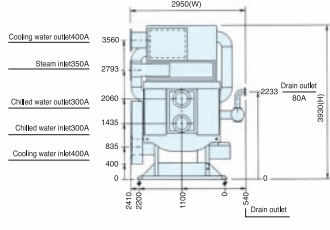
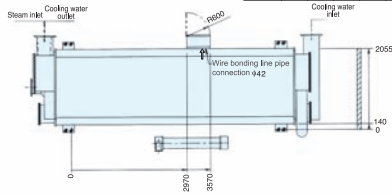

## DXG-81/82

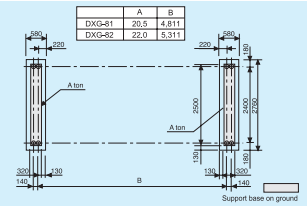

	A	B	C	D	E
DXG-81	7080	4811	4951	5651	6500
DXG-82	7580	5311	5451	6161	7000

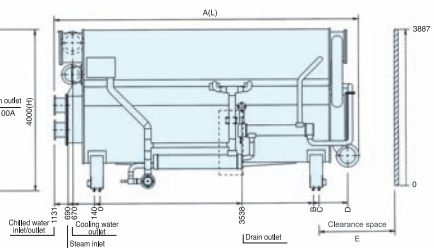
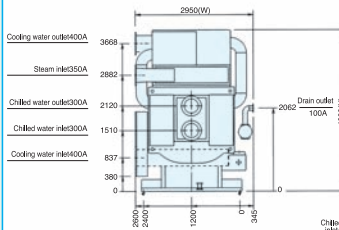
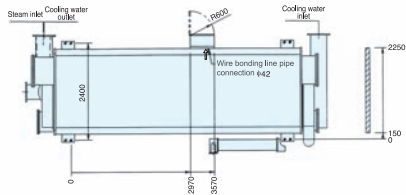

## Overall dimension diagram · Base diagram / Heat/cooling insulation area

## DXG-83/84 In ( ) is Model 84

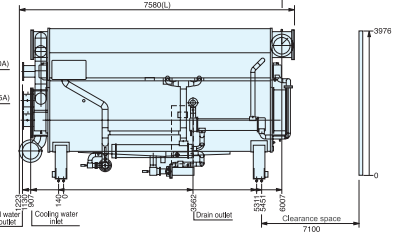
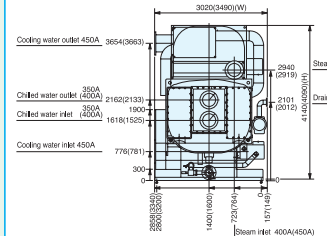
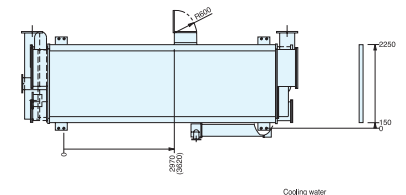
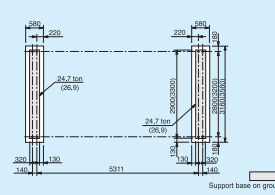

## Heat/cooling insulation area

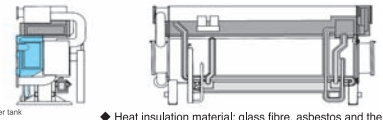
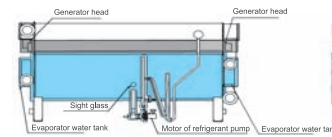

- 75mm heat insulation: high temperature generator, low temperature generator, steam pipe etc.
- 30mm heat insulation: heat exchanger, connecting pipes, etc.
- 50mm cooling insulation: evaporator, evaporator water tank, etc.
- 30mm cooling insulation: upper part of refrigerant pump, connecting pipes, etc.

Partition	Model	Heat insulation area (m <sup>2</sup> )		Cooling insulation area (m <sup>2</sup> )	
		75mm	30mm	50mm	30mm
DXG-11	2.8	1.6	4.0	0.3	
DXG-12	2.8	1.8	4.0	0.3	
DXG-13	3.8	1.9	5.5	0.3	
DXG-14	3.8	2.2	5.5	0.3	
DXG-21	4.0	2.5	6.1	0.4	
DXG-22	4.0	2.5	6.1	0.4	
DXG-23	5.2	3.1	7.6	0.5	
DXG-24	5.2	3.3	7.6	0.5	
DXG-31	6.0	3.5	8.5	0.5	
DXG-32	6.0	3.6	8.5	0.5	
DXG-41	6.6	3.7	9.9	0.5	
DXG-42	6.6	3.9	9.9	0.5	
DXG-51	7.6	4.8	13.8	0.7	

- Heat insulation material: glass fibre, asbestos and the like.
- Cooling insulation material: polythene foam and the like.
- Heat/cooling insulation total area includes machine pipe area.
- Please use non-combustible as heat/cooling material.
- In above drawing, DXG-11 ~ 63 is indicated.
- For others detail see ex-works file.
- Don't make cooling insulation for motor of refrigerant pump and sight glass.
- Please make the part in dotted square removable structure: evaporator water tank, generator head, etc.

Partition	Model	Heat insulation area (m <sup>2</sup> )		Cooling insulation area (m <sup>2</sup> )	
		75mm	30mm	50mm	30mm
DXG-52	8.4	5.1	15.0	0.7	
DXG-53	9.2	5.3	16.1	0.7	
DXG-61	15.7	8.0	17.7	0.9	
DXG-62	16.9	8.2	20.1	0.9	
DXG-63	18.5	8.5	21.2	0.9	
DXG-71	19.4	10.1	10.8	1.2	
DXG-72	21.3	10.3	11.3	1.2	
DXG-73	22.9	10.5	11.7	1.2	
DXG-81	26.8	11.0	13.1	1.5	
DXG-82	28.6	11.2	13.6	1.5	
DXG-83	30.2	13.7	15.7	1.75	
DXG-84	32.5	16.2	16.3	2.0	